

CM-8010

Instruções de Montagem Assembly Instructions Instrucciones de Armado

Acesse Vídeos de Montagens
Access Mounting Videos
Acceder a los Vídeos de Montage
www.tecnomobili.ind.br

tecnomobili

Estrada RSC 453, Km s/nº | Garibaldi | RS
CEP: 95720-000 | Fone / Fax: 54.3464.2050
sac@moveisvideira.com.br

Lista de Peças / List of pieces / Lista de piezas

CóD	DESCRIÇÃO	DESCRIPTION	DESCRIPCIÓN	QTD	RAW MATERIAL	DIMENSION	CÓD
01	Cabeceira Superior	Upper Headboard	Cabecera Superior	1	MDP 15mm	986x252x15mm	718010
02	Cabeceira Inferior	Bottom Headboard	Cabecera Inferior	1	MDP 15mm	986x252x15mm	708010
03	Pé Cabeceira Esquerdo	Left Foot Headboard	Pié Izquierdo Cabecera	1	MDP 25mm	900x65x25mm	308010
04	Pé Cabeceira Direito	Right Foot Headboard	Pié Derecho Cabecera	1	MDP 25mm	900x65x25mm	318010
05	Travessa Cabeceira	Headboard Traverse	Traviesa Cabecera	1	MDP 15mm	986x45x15mm	608010
06	Aplik	Aplik	Aplik	3	MDP 15mm	982x22,5x15mm	858010
07	Lateral	Side	Lateral	2	MDP 25mm	1900x126x25mm	338000
08	Travessa Dianteira	Front Traverse	Traviesa Delante	1	MDP 15mm	834x160x15mm	608005
09	Pé Dianteiro Esquerdo	Left Front Foot	Pié Delante Izquierdo	1	MDP 25mm	385x65x25mm	328004
10	Pé Dianteiro Direito	Right Front Foot	Pié Delante Derecho	1	MDP 25mm	385x65x25mm	338004
11	Lastro	Ballast	Lastre	10	Madeira	900x70x10mm	9543
12	Suporte para Lastro	Ballast Suport	Soporte Lastre	4	Madeira	900x40x22mm	9697

Notas Especiais:

01 -Examine completamente todas as peças do móvel antes de começar o trabalho.

02 -Recomenda-se montar o móvel conforme este Manual de Montagem.

03 -É de responsabilidade do montador seguir as instruções do Manual de Montagem, que são fundamentais para garantir a estrutura do móvel.

04 -Para limpeza, utilizar somente pano úmido e sabão neutro.

Special notes:

01 -Check all parts of the unit thoroughly before starting work.

02 -It is recommended to assemble the furniture according to this Installation Manual.

03 -It is the responsibility of the assembler to follow the instructions in the Assembly Manual, which are essential to ensure the structure of the furniture.

04 -For cleaning use only damp cloth and neutral soap.

Notas especiales:

01 -Examine completamente todas las piezas del mueble antes de iniciar el trabajo.

02 -Se recomienda montar el mueble conforme el Manual de Ensamblaje.

03 -Es de responsabilidad del montador seguir las instrucciones del Manual de Ensamblaje, que son fundamentales para garantizar la estructura del mueble.

04 -Para limpieza solamente usar trapo húmedo y jabón neutro.

Guarante certificate:

The guarantee of products manufactured by Móveis Videira LTDA covers any defects / manufacturing defects, within the period established by the Consumer Protection Code, in its Article 26, II, which provides for a legal guarantee of ninety (90) days.

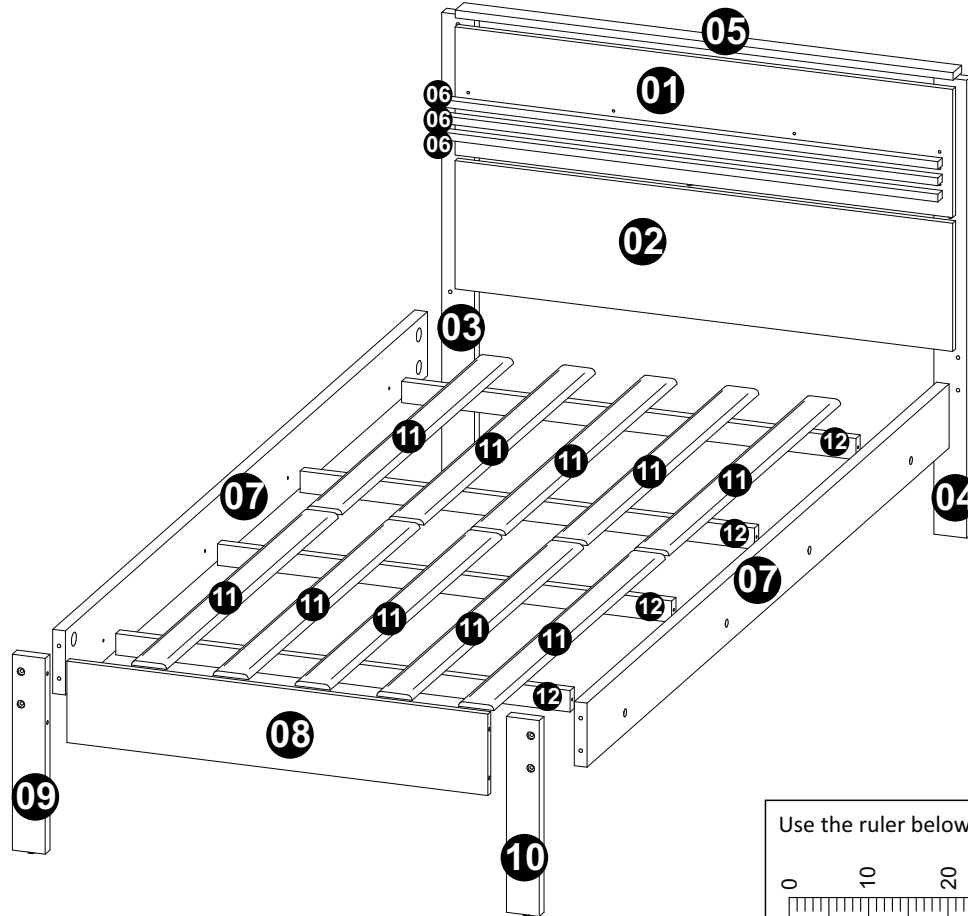

LUSTRAÇÃO - ILUSTRACION - ILLUSTRATION

A		35 x 9,5 x 7mm Porca Meia Lua	08	
B		4,0 x 50mm CF	08	2070
C		1/4 x 70mm	08	8672
D		62 x 7mm Minifix Haste Dupla	04	8991
E		15 x 12mm Tambor Minifix	08	9516
F		22 x 3mm Prego 10x10	24	3051
G		14 x 4mm Sapata Deslizadora	04	8112
H		25,6 x 40mm Suporte para Lastro	08	
I		34 x 47mm Chaveta Sextavada	01	
J		Parafuso 5 x 35mm CF	08	2263
K		Tapa Furo	12	
L		Cavilha 8 x 30mm	08	2806
M		22x17x12mm	03	3572
N		Parafuso 3,5 x 14mm CF	16	3759
O		32mm Chapa Metálica 42x14x1,2mm	01	8889
P		Parafuso 3,5 x 25mm	12	0286

Ferramentas | Tools | Herramientas

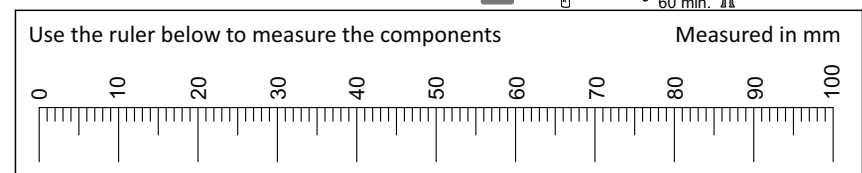

Revisão: 00
Data: 07/10/2021

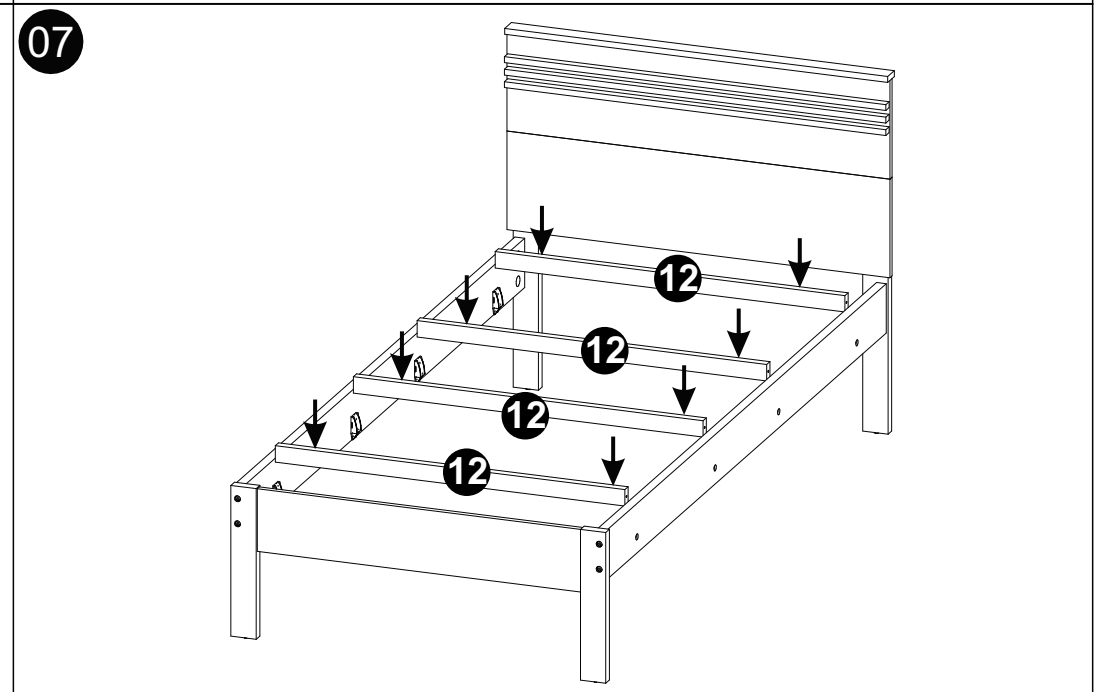
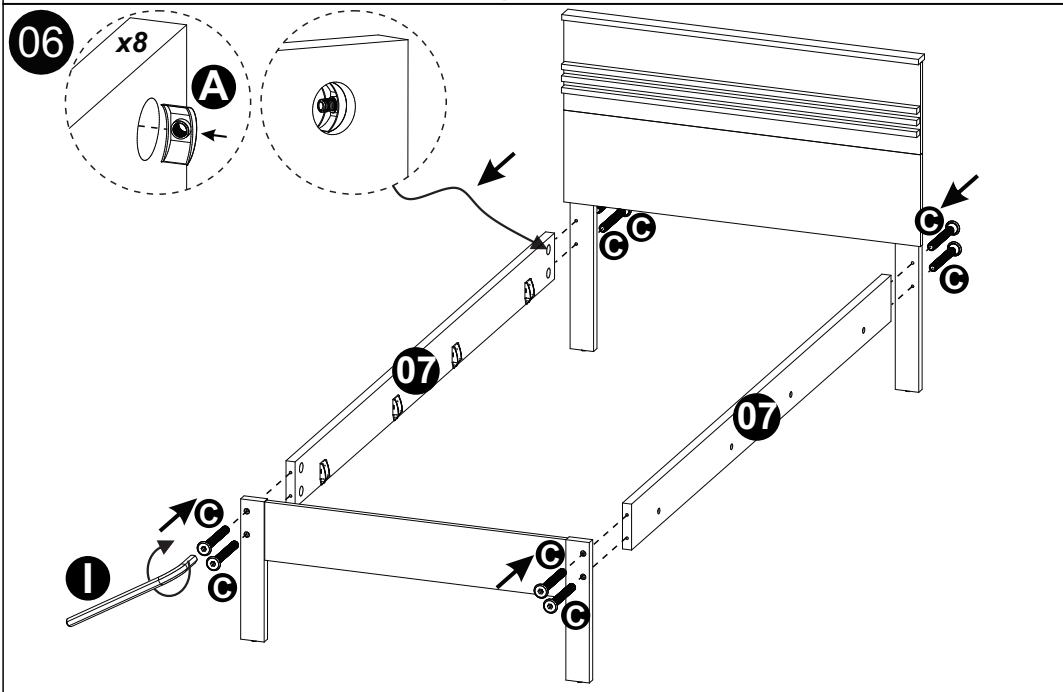
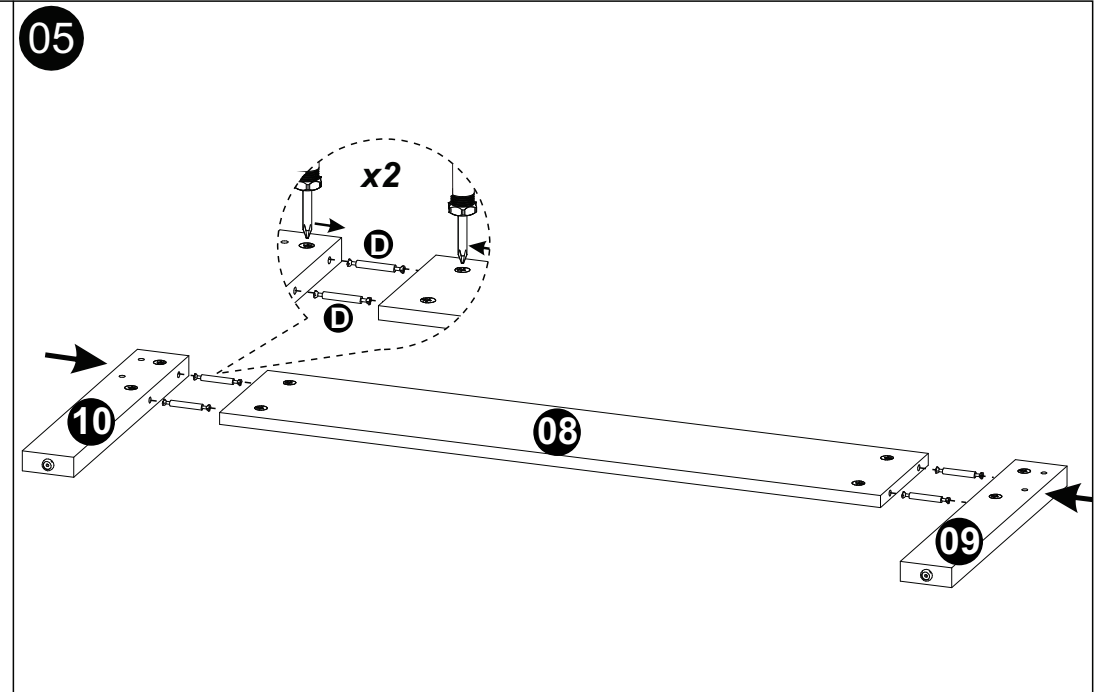
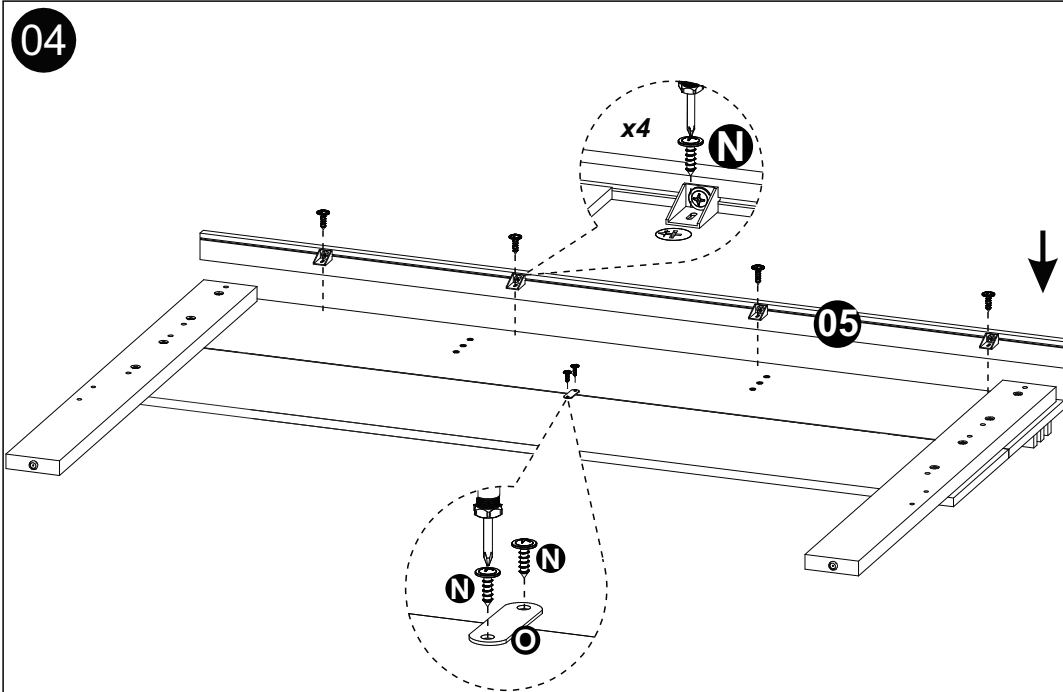

08

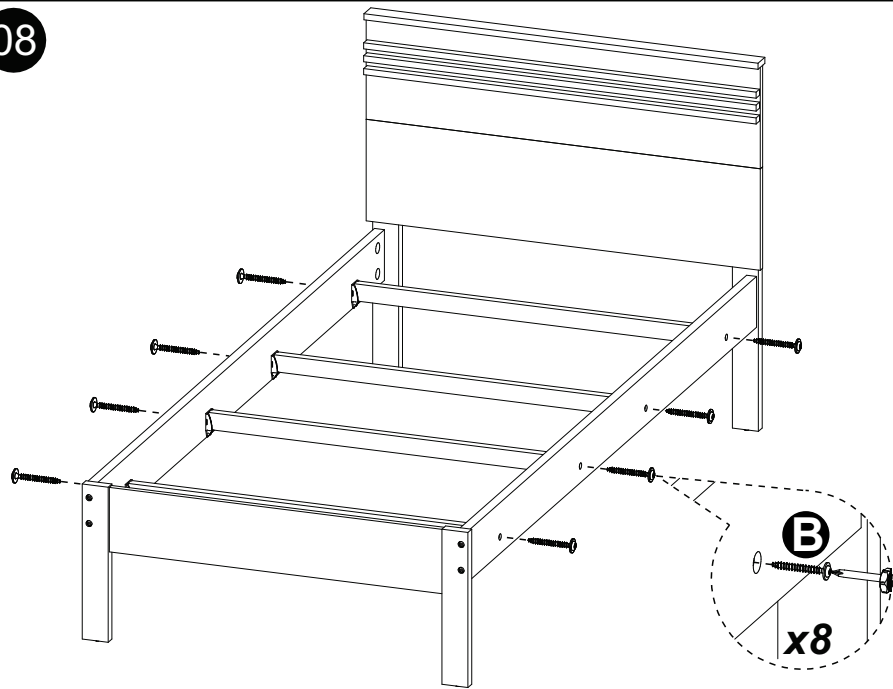

09

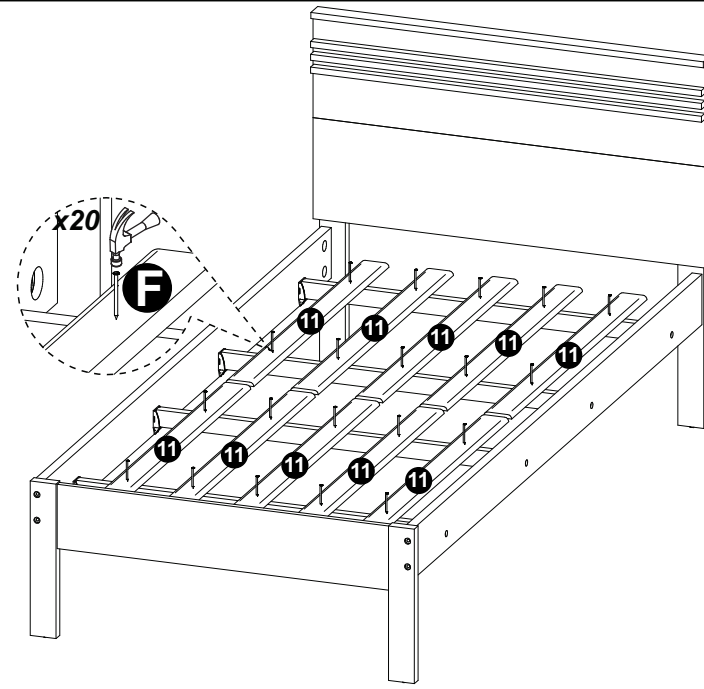

10

